



## RIO Zuni™ Specifications

This compact, easy to install and operate on-site chemical generator is designed for minimal maintenance and ultimate simplicity. The RIO Zuni features less than 3 maintenance hours in 6 months, an extremely small footprint, can handle a higher water hardness with minimal conditioning, and has an optional integrated brine tank and remote monitoring capabilities. Just load with salt and let the RIO Zuni do the dirty work for you! .

	RIO Zuni 1	RIO Zuni 2
Rated FAC Capacity	1.0 lbs/day 0.45 kg/day	2.0 lbs/day 0.9 kg/day
Water Treatment Capacity (at 1 ppm FAC)	120,000 gal/day 454 m <sup>3</sup> /day	240,000 gal/day 908 m <sup>3</sup> /day
Salt Conversion (SCE)*	3.0 - 3.5 lb salt/lb FAC 3.0 - 3.5 kg salt/kg FAC	
Energy Conversion (ECE)*	3.5 kW-hr/lb FAC 7.7 kW-hr/kg FAC	
FAC Concentration*	4,000 mg/L (+/- 1,000)	
Salt Quality Requirement	99.5% NaCl or better^	
Water Hardness	0-51 mg/L	
Flow Rate	1.3 gph (+/- 15%) 4.9 lph (+/- 15%)	2.7 gph (+/- 15%) 10.2 lph (+/- 15%)
Electrical Service Requirement+ (OSG Only)	110 VAC to 240 VAC, 1 ph, 4A, 50/60 hertz	110 VAC to 240 VAC, 1 ph, 8A, 50/60 hertz
Air Temperature Required	40°F to 120°F 4°C to 49°C	
Recommended Feed Water Temperature*	55° to 80° F 12° to 26.7° C	
Allowable Feed Water Temperature*	40° to 95° F 4° to 35° C	
Feed Water Pressure	1 - 75 psi 6.8 – 517 kPa	
Approximate OSG Dimensions (WxDxH)	20.75 x 15.66 x 13.5 inches 52.71 x 39.78 x 34.29 cm	
Approximate OSG Weight	25 lbs 11.5 kg	
Self Cleaning	YES	

+For continued protection against risk of fire, replace fuse only with a fuse of the same type and current rating

\*Performance may vary depending on salt quality, water quality, and water temperature.

^Refer to MIOX Salt Quality Guidelines for more details.

**Note: This electronic document is controlled. Once this document is printed it becomes uncontrolled and obsolete. Refer only to electronic document for the latest information.**



## RIO Zuni Drawing

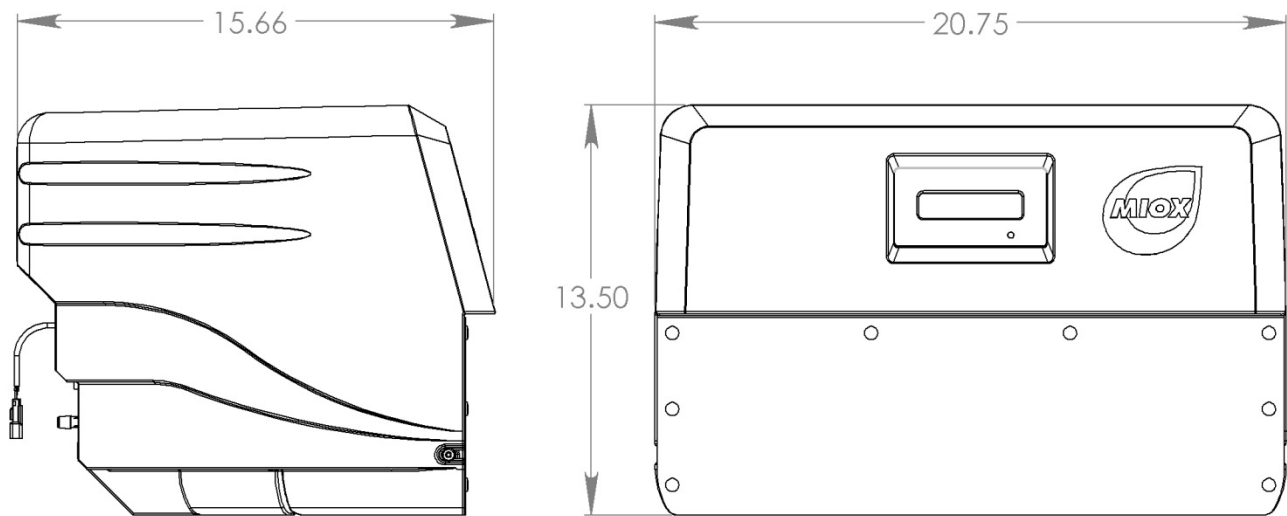

REFERENCE GENERAL ARRANGEMENT DRAWING 112-00022  
FOR INSTALLATION REQUIREMENTS

**Note: This electronic document is controlled. Once this document is printed it becomes uncontrolled and obsolete. Refer only to electronic document for the latest information.**

