

PosiFlow® Sensor

Read this manual before using product.

1.0 PRODUCT DESCRIPTION

The PosiFlow® Sensor will verify that your metering pump is truly moving liquid into the system and has not lost prime. Utilizing proprietary circuitry coupled with advanced pressure sensing technology, the PosiFlow® Sensor provides the most accurate and non-intrusive flow verification device to date. Without any moving parts in the sensor, the standard flow path of the pump is preserved and the liquid does not move through any gears or lift a magnet to actuate a pulse in the sensor. This eliminates any concern of plugging, leaking or jamming of the flow path or sensing mechanism.

The output signal of the PosiFlow® Sensor is an open-collector contact closure corresponding with each flow pulse. Additionally, a visual LED is mounted on the topside of the sensor. The LED is normally OFF, flashing green in sync with each output signal, and turns Red during abnormal pressure conditions.

The PosiFlow® will send out a signal with every stroke as long as there is liquid pumping against pressure. If the pump becomes either air-locked or in a dead head condition, the sensor will no longer output a signal. And unlike the competition, if the discharge line breaks or becomes disconnected, pressure will be lost and the PosiFlow® sensor will stop signaling flow.

2.0 SAFETY & CAUTION NOTES

NOT OBSERVING PRECAUTIONS MAY CAUSE INJURY OR DAMAGE TO THE PRODUCT.



Wear Protection

When working on or around a metering pump, always wear proper protective clothing and equipment as recommended by the supplier of the chemical being pumped.



Remove Power

Disconnect the pump and sensor from their electrical power sources before performing any maintenance. If the pump starts operation during maintenance, chemical may be sprayed & cause injury.



Application of Product

Use the PosiFlow® within the specified range. Using the PosiFlow® in any other application than its intended purpose may result in personal injury or damage to the product.



Power Source

Use only stable DC voltage within the specified range. Voltage outside the range may cause damage or fire.



Do Not Modify the Product

Never attempt to modify the PosiFlow®. Alteration of the product may produce a dangerous situation and will void the warranty.



Location

Do not use the PosiFlow® Sensor in an aggressive environment. Exposure to liquid or excess humidity may cause failure or electrical shock.



Do Not Use a Damaged Sensor

Using a damaged PosiFlow® may cause chemical leakage or electrical shock.

3.0 SPECIFICATIONS

1. Identification:

Part Number	Description	Material
FCP-1VC	PosiFlow [®] Sensor, VC	VC
FCP-1VE	PosiFlow [®] Sensor, VE	VE
FCP-1PC	PosiFlow [®] Sensor, PC	PC
FCP-1PE	PosiFlow [®] Sensor, PE	PE

2. Applicable Models and Ordering Information:

The PosiFlow[®] Sensor is available for direct mounting in the 11, 16 & 21 sizes of E Series pumps with matching liquid end codes. It will mount into either the manual air vent valve or the Multi-Function valve. Installation with other sizes or auto air vent valve models can be accommodated with an in-line mounting adapter.

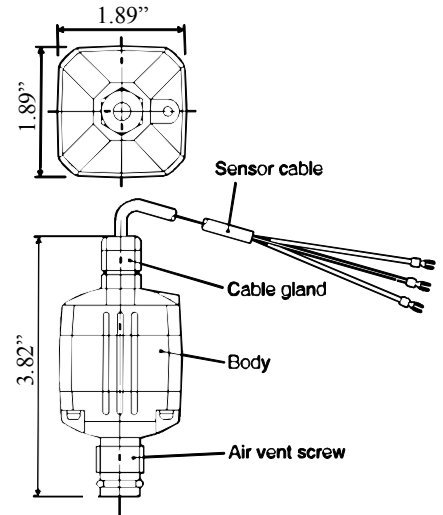

3. Electrical

Power Source Voltage	12VDC ±2VDC
Current	25mA max (@12VDC)
Output Type	Non-Isol. Open Collector (NPN)
Rating	24VDC max (from source)
Wave Form	100mS ±15mS
Indicator	LED (Green)
Cable Length	9.75 Feet
Cross Section	3.1x10 ⁻⁴ in ²
Termination	#6 Fork Terminal

5. Output Pressure Range*

35 PSI to 150 ± 15 PSI

6. Environment:

Ambient Temperature	0-120°F
Ambient Humidity	35-90% RH
Storage Temperature	32-120°F
Liquid Temperature	32-105°F (PVC models)
Viscosity Limit	200cps

4. Materials of Construction

Housing	PVC or GFRPP
O-Rings	FKM or EPDM
Sensor	96% Ceramic (Al ₂ O ₃)

*The PosiFlow[®] Sensor requires a minimum of 35 PSI total back pressure. If this is not available, the injection valve supplied with the pump can be retrofitted with an optional high-pressure spring, part number E90375. This spring will increase the back pressure at the pump approximately 50 PSI.

4.0 INSTALLATION



Disconnect the pump from the electrical power source before performing maintenance.



Release the pressure in the discharge tubing before disconnecting or performing any maintenance on the pump.

Plumbing

1. Unscrew and remove the air vent knob from the manual air vent valve (or Multi-Function Valve) by turning counter-clockwise.
2. Insert the PosiFlow[®] Sensor directly where the air vent knob was located (turn clockwise to secure).

⚠ CAUTION: The wires on the sensor will want to twist as it is being screwed into the valve. While installing the sensor, also turn the cable to avoid wire twisting and damage. If this is not possible, pre-twist the wire in the opposite direction about 5 turns to relieve stress during sensor installation.

- The function of the manual air vent is not lost when using the PosiFlow[®] Sensor. Simply use the sensor itself as the manual air vent valve when necessary, turning it one-half to one turn counter clockwise to bleed out air, prime the pump or release the discharge pressure.



Installing the PosiFlow[®] Sensor into the manual air vent valve.



Installing the PosiFlow[®] Sensor into the Multi-Function Valve.

Electrical Wiring

The PosiFlow[®] Sensor requires 12VDC power to operate. Attach the RED wire to +12VDC and the BLACK wire to GND (common). The output signal is a closed contact between the WHITE and BLACK wires.

⚠ CAUTION: Do not run the PosiFlow[®] cable near other power lines carrying high current or high power equipment as line noise can cause sensor damage or abnormal operation.

Output Signal

The output signal (white wire) is normally high and drops to zero when the PosiFlow[®] senses a pulse from the discharge of the pump. The time of the closed contact is 100mS. See the output wave form below.

This type of signal acts similar to a contact closure from a reed switch device between the signal (white) and the common (black) wires. The only difference is that the receiving device will see a trigger on the rise of the output instead of the fall (reverse of typical).

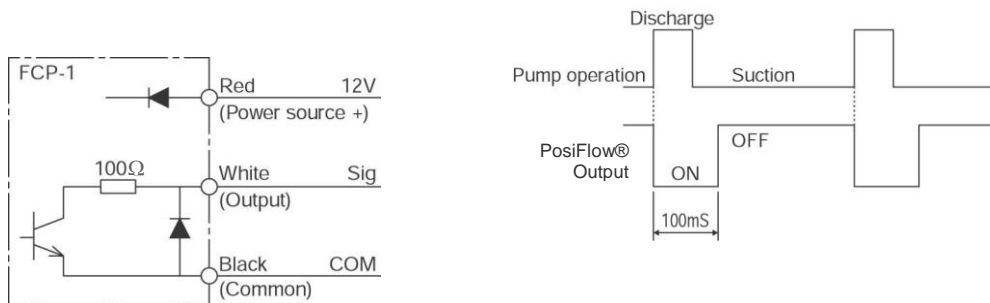

5.0 OPERATION

Back Pressure Requirement

In order for the PosiFlow[®] Sensor to function, a minimum of 35 PSI system pressure is required at the sensor. In cases where there is little or no system pressure, the standard injection check valve supplied with each pump can be modified with a high-pressure spring that adds approximately 50 PSI. Contact your local distributor to order Part Number E90375.

Operation

Turn on the pump. The PosiFlow[®] will not output a signal until the pump actually is moving liquid. For priming of the pump, the PosiFlow[®] sensor may have to be turned one-half or one full turn counter-clockwise to vent the air out the vent connection.

⚠ CAUTION: Tubing should always be connected from the air vent back into the supply tank or suitable drain. Do not submerge the air return tubing below the chemical surface level in the supply tank.

Once fully primed, close the air vent by tightening down the PosiFlow[®] Sensor. The green LED on the PosiFlow[®] should begin to flash OFF with each pump stroke and it will output a pulse simultaneously. The PosiFlow[®] will continue to output pulses as long as it senses pressure changes. If the pump loses prime or is air locked, the compression of air with each pump stroke will not generate enough pressure for the PosiFlow[®] to sense, the LED will turn red, and it will not output pulses. Similarly, excessive pressures will cause the pump to begin to stall and not generate enough pressure differential for the PosiFlow[®] to sense.

NOTE: If there is any trapped air, long lengths of flexible tubing, or any area of relief or expansion during a deadhead situation, the PosiFlow[®] may still keep sensing flow. This is more likely in C16/21 sized pumps.

Output Signal

The output signal from the PosiFlow[®] simulates a contact closure. It can be used in any device that takes a non-powered contact closure as a switch. It can also be used to drive another E Series pump.

The Walchem WebMaster[®] is designed to accept the PosiFlow[®] Sensor signal. It both powers and reads the signal. The WebMaster[®] will alarm a no flow condition after a customer-set time limit and will also totalize pumped volume once the pump is calibrated.

In a similar manner, a PLC or other device can be programmed to interpret the PosiFlow[®] signal in any number of ways.

6.0 TROUBLESHOOTING & MAINTENANCE

⚠ CAUTION: Do NOT disassemble the PosiFlow[®] Sensor! There are no user serviceable parts inside and the components can easily be damaged. Disassembly of the Sensor will void the manufacturer's warranty.

Problem	Possible Cause	Corrective Action
No output pulses from the PosiFlow [®] Sensor (Output pulse is not synchronous with the pump stroke or LED is red)	Incorrect or disconnected wiring	Double check wire connections
	Pump has lost prime (air-lock)	Unscrew PosiFlow [®] one-half turn to vent air
	Pump is drawing in air	Check the tubing and fitting connections
	Disconnected or cut tubing	Correct/Replace the tubing
	Pinched or clogged tubing	Correct/Replace Tubing
	Foreign material lodged in pump	Disassemble/inspect/clean pump head assembly
	PosiFlow [®] Sensor not tightened down (in the air vent condition)	Tighten the PosiFlow [®] Sensor by turning clockwise by hand.
Liquid Leakage from around the PosiFlow [®] Sensor	Not enough back pressure	Check Injection Valve location and system pressure. Install the High Pressure Spring (E90375) if there is little or no system pressure. 35 PSI back pressure is required.
	O-ring seals on PosiFlow [®] missing, dislocated, or worn	Re-install or replace the o-rings